

Cryolithionite
and Li in the Cryolite Deposit
Iviglut, South Greenland

By HANS PAULY



Matematisk-fysiske Meddelelser **42:1**

Det Kongelige Danske Videnskabernes Selskab
The Royal Danish Academy of Sciences and Letters

Commissioner: Munksgaard · Copenhagen 1986

Abstract

Cryolithionite always occurred as single crystals in cryolite: idiomorphic, subidiomorphic and, rarely, anhedral. It was found in siderite-cryolite; in a variety of this type: black cryolite with red-brown Th-containing fluorite, siderite etc. (BCrBf); in pure, white cryolite; in cryolite veining the wall rocks. It belongs to the period in which siderite-cryolite formed.

Analyses of 268 cryolite samples gave 92 ppm Li (min. 19, max. 224 ppm). Cryolite from samples with cryolithionite: 81 ppm, cryolite from BCrbF with no cryolithionite: 185 ppm.

Cryolithionite seems to have formed by exsolution from cryolite with 155 ppm Li or more. The high contraction of cryolite on cooling (1 vol% pr. 100°C) may have given rise to low-pressure regions within the cryolite where cryolithionite ($d = 2.77$) replaced cryolite ($d = 2.97$) after formation of the complicated twin structures in the cryolite - at or below 450°C. The compound $\text{Na}_2\text{LiAlF}_6$ ($d = 3.02$) is not present in the deposit.

HANS PAULY

Technical University of Denmark
bg.204, DK-2800 Lyngby
Denmark

Keywords:

Cryolithionite, Li in cryolite, siderite-cryolite, Th-containing fluorite, black cryolite, Ivigtut, South-Greenland.

List of Contents

Introduction	3
Cryolithionite in the deposit	3
In situ observations of cryolithionite	6
The cryolite deposit at Ivigtut	7
Appearance of cryolithionite, its outer shape, mineral and fluid inclusions	11
Formation of cryolithionite	17
Li in cryolite and other minerals of the Ivigtut deposit	18
Cryolithionite formed by exsolution from cryolite	19
Acknowledgments	23
Literature	23

Introduction

Cryolithionite, Ussing 1904, was first described from samples of pure white cryolite and from samples with only small amounts of siderite and sulphides. Bøggild (1913) reported its occurrence in black cryolite giving no further details as to paragenesis or localization in the deposit.

Several crystallographic studies and studies of the phase diagrams of the systems to which the compound belongs have been carried out since the mineral was discovered. The paragenetic position has, however, hitherto been obscure.

The following is an attempt to clarify the situation concerning the types of cryolite in which cryolithionite occurred and the relations of the mineral to its surroundings. Based on these observations and the general ideas of the formation of the deposit in Ivigtut the mode of formation of the cryolithionite is considered.

The sources, apart from the very few published works, are unpublished reports from the mine managers to the Cryolite Company, notes by the late chief geologist Mr. R. Bøgvad and the author's own observations made during the last ten years of operation in the mine which closed in 1962. The temporary reopening of the mine during the last few years has not provided additional information.

Cryolithionite in the cryolite deposit

In 1902 cryolithionite was found as inclusions in cryolite in the foot of the western wall of the quarry 34.5 m below sea level. Fig. 1 shows the first sample sent from Ivigtut the 25th of October 1902 by the mine manager Mr. E. F. Edwards. He accompanied the sample with the following report (in translation): "A block of cryolite from the NW corner of the quarry 110' below sea level, which is peculiar because, in the center of the block occurs a cavity filled with water-clear cryolite suspended in which the common minerals galena, siderite etc. are found. The box is marked Mineral N^o 1, 1902".

This block, now in the Geological Museum of the University of Copenhagen, is mentioned by Ussing (1904) who found that the "water-clear cryolite" was indeed a new mineral. He named it cryolithionite following a proposal by the famous Danish

chemist Julius Thomsen, then director of the Cryolite Company, who found that this name emphasized the resemblance to cryolite and the considerable content of Li. In his concluding remarks Ussing (1904) stressed, however, the crystallographic dissimilarities between the two minerals and emphasized analogies between garnets and the new mineral. Crystal structure determinations (Menzer 1927, 1930 and Geller 1971) unambiguously demonstrated the garnet structure of cryolithionite.

In the autumn of 1903 Mr. Edwards sent further samples of the new mineral reporting that it could now be found all along the SW border of the quarry "so far only in spots". We have no indications that further samples were recovered from these surroundings.

The existing samples show that cryolithionite appeared as rather large areas of hexagonal outline in white cryolite, up to 17 cm across, see Fig. 1. Scattered in this cryolite, isolated grains of siderite and some sulphides were present in small amounts. This and the location in the quarry taken together with reports on the development of the mine in the years 1889, 1894, 1904 and 1911 indicate that cryolithionite occurred in the transition zone between the siderite-quartz-sulphide bearing cryolite (siderite-cryolite) and a body of pure, white cryolite which was being exposed in the bottom of the western part of the pit in the first years of this century, 34 m below sea level.

Bøggild (1913) pointed out that cryolithionite in the intervening years had been found also in black cryolite where the white crystals of the mineral stood out quite conspicuously. These samples undoubtedly came from the mining of a peculiar variety of the siderite-cryolite, exposed in 1889 in the bottom of the quarry, about 28 m below sea level. Besides the usual impurity minerals of the siderite-cryolite, cm-sized crystals of red-brown fluorite constituted 5 to 10% of the mass. According to a map and a profile drawing, see Fig. 2, sent from Ivigtut to the company in 1889, and some photographs taken in the period from 1890 to 1908, this peculiar variety of siderite-cryolite (in the following named BCrbF for black cryolite with red-brown fluorite) constituted an inclined, interrupted sheet through the siderite-cryolite, the only cryolite type then exposed in the quarry. The sheet was several metres thick and about 30 to 40 metres wide and long. In the western wall it was exposed about 20 m below sea level.

The red-brown fluorite in the BCrbF had been observed in 1873 by Lieutenant S. Fritz (manager in Ivigtut 1866-79) in a shaft (started in 1867 from the surface) at a depth of 28 m where mining in 1889 eventually revealed its nature as an inclined sheet; Johnstrup (1880) mentioned the occurrence of this fluorite. Thomsen (1904) published a note on gases contained in some Greenlandic minerals where he, i.a., showed the presence of He in this fluorite. A few years later Jarl (1910) found that the fluorite was radioactive. Pauly (1960) reported a content of nearly 0.3% Th in the red-brown fluorite. The black colour of the cryolite is attributed to the irradiation (Pauly 1962).

Cryolithionite in BCrbF constitutes a significant part of the total number of samples of this rare mineral in the collections kept in Denmark.

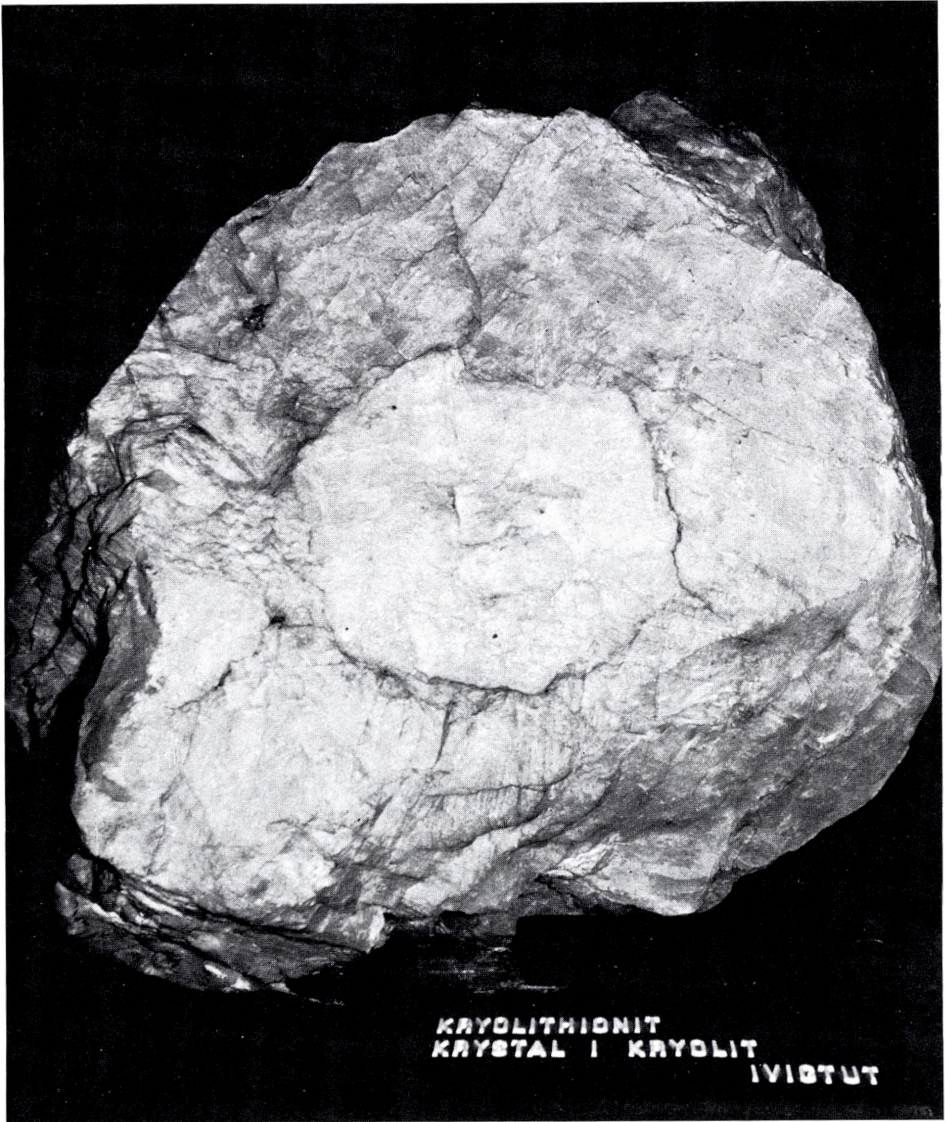

Fig. 1. Cryolithionite crystal in cryolite. Siderite is present in the cryolite of the back side of the sample. This sample was collected in Ivigtut in the year 1902. Largest diameter of crystal 17 cm.

In situ observations of cryolithionite

In 1931 cryolithionite was observed in black cryolite in the pegmatite area where cryolite mining had been attempted since 1867 through shaft sinking and drifting at sea level. The shaft and part of a mined-out room was still accessible in 1931 when Mr. R. Bøgvad first visited Ivigtut. In an unpublished note he reported the observation of 10 crystals of cryolithionite (one of which was 8 cm across) in the black cryolite making up most of the roof and the northern wall of the mined-out room (about 10 m long and a few m wide and high). Fragments of quartz with cassiterite, and feldspar were also embedded in the cryolite showing that brecciated parts of the pegmatite had been cemented by the cryolite carrying the cryolithionite. Siderite and sulphides were present in other parts of the drift.

Some years later veins of smoky to black, pure cryolite in the rocks of the granite intrusion adjacent to the cryolite mass in the southern wall of the quarry were found to contain scattered crystals of cryolithionite. In places crystals could be found at intervals of about one meter.

The cryolite of these veins merged with cryolite cementing a huge chimney-like wall-rock breccia which extended from the bottom of the pit some fifty metres below sea level to the surface 10 metres above sea level. A corresponding chimney-like breccia was observed in the NW corner of the pit in 1953. When mining operations in the following years disclosed the border between the cryolite mass and the surrounding rocks of the intrusion in the lower part of the wall between the two breccias the wall-rock was seen to be heavily fragmented and cemented by smoky to black cryolite. Cryolithionite has been found here and there in these veins and in cements of cryolite which otherwise was quite pure. The darkening of the cryolite in these surroundings is attributed to irradiation from Th-containing zircon in the rock fragments which have been found to contain about 300 ppm Th and about 80 ppm U.

One crystal of cryolithionite has been observed in siderite-cryolite exposed in the NE part of the quarry 10 m below sea level. In the same part of the deposit two crystals were found in a drill core at a level of 42 m below sea level. A drilling in the S part of the deposit picked up a crystal 52 m below sea level, also in siderite-cryolite.

Cryolithionite has also been found in two cores from drillings set in cryolite carrying fluorite and fine-grained topaz and K-mica (the so-called fluorite-cryolite). Both drillings were located in the NW part of the deposit. The one crystal was found 55 m and the other 62 m below sea level.

Finally in situ observations of cryolithionite were also made in two survey drifts set in the foot of the N wall of the pit 55 m below sea level. In both cases the crystals were situated in high grade fluorite-cryolite.

The positions of the various finds of cryolithionite are marked on the map, Fig. 2.

The major part of the material for examination is not strictly localized in the deposit

but is generally samples collected loose in the quarry (i.e. after blasting) and in the piles of crude ore. It can be classified as belonging to one of the following environments:

1. Black cryolite with red-brown fluorite (BCr₂F₆).
2. Siderite-cryolite.
3. Transition zone between siderite-cryolite and the body of pure, white cryolite.
4. Vein cryolite and cryolite acting as a cement in breccias.
5. Fluorite-cryolite.

The cryolite deposit at Ivigtut

Cryolite and accompanying minerals were present in the top part of a granite stock, 300 m in diameter, as a plano-convex lens-shaped body nearly circular in cross section, diameter about 170 m and up to 70 m thick. The uppermost part of the lens was exposed at sea level, but a funnel shaped protrusion, extending some 50 metres to the east, rose to about 5 m above sea level (see map and longitudinal section, Fig. 2). The western part of the lens was covered by a pegmatite composed of mainly quartz and microcline. The upper two thirds of the cryolite body consisted of siderite-cryolite, that is cryolite carrying siderite as the main impurity together with a few percent sulphides and quartz (Pauly 1960). The lower western part of the lens consisted of fluorite-cryolite, so called because fluorite was the main impurity accompanied by microcrystalline topaz and K-mica; several other minerals were present but siderite and the sulphides accompanying the carbonate did not occur in this cryolite type.

Intercalated between the fluorite-cryolite and the siderite-cryolite occurred a body of pure, white cryolite about 150 m long, up to 70 m wide and 40 m thick.

Consolidation of the siderite-cryolite took place at temperatures above 500°C (Pauly 1960, Oen & Pauly 1967). Part of the fluorite-cryolite consolidated at temperatures around 300°C (Karup-Møller 1973).

In a general way consolidation seems to have proceeded from east to west. The earliest formed siderite-cryolite, in the eastern protrusion, cemented a wallrock breccia. The main body of siderite-cryolite developed under rather quiet conditions. This is indicated by a pronounced banding or layering constituted by alternating siderite-rich and siderite-poor m-thick layers. The layers were conformable with the upper surface of the lens, i.e. its contact with the rocks of the intrusion, over distances up to 80 m (Holst 1886, Baldauf 1910, see also Pauly 1986).

The peculiar variety of siderite-cryolite, BCr₂F₆, is assumed to belong to the earlier formed parts of the siderite-cryolite in spite of its position, see Fig. 2: BCr₂F₆ was found to enclose a m-sized xenolith of granite like the siderite-cryolite in the eastern protrusion (Edwards, unpublished report 1894); moreover R. Bøgvold found, according to an

unpublished note from 1945, sharply delineated, m-sized blocks of BCrbF enclosed in siderite-rich cryolite in the S-wall of the quarry some 50 m below sea level.

The body of pure, white cryolite, as it appeared in the first years of the 1920's when it was an important object for the mining, was regarded as secondary vis-a-vis the siderite-cryolite (Corp 1928). Observations elsewhere in the mine of m-wide veins of pure, white cryolite transecting siderite-cryolite may have inspired the mentioned point of view. The appearance of the remains of the body of the pure, white cryolite during the last decade of mining operations led the present author to the conclusion that it represented the last product of the period in which siderite-cryolite formed.

The fluorite-cryolite was termed "the fluorspar-breccia" in the late 1920's when it was first exposed in the mine. The brecciated nature was evident throughout the whole mass of this material. Part of it contained about 90% cryolite and some percent fluorite; microcrystalline topaz and K-mica in mm-wide veins formed a three-dimensional network through the cryolite which appeared as sharp-edged blocks one to several dm across. This variety was found next to the body of white, pure cryolite. Away from this body occurred lower grade fluorite-cryolite varieties containing dm-sized aggregates of fluorite, weberite, K-mica etc. The aggregates as well as the cryolite were transected by veins and stringers of topaz and/or K-mica. Jarlite, baryte, thomsenolite etc. occurred in some of the aggregates characterized by the presence of voids and crystal-lined druses; in the deepest parts of the fluorite-cryolite, compact masses of prosopite with pores and cavities lined with crystals were found (mentioned in Leonardsen et al. 1980).

When fluorite-cryolite bordered against siderite-cryolite the latter was brecciated, siderite was transformed into hematite and magnetite, in places to pyrite, and a number of chemical reactions took place including the replacement of quartz by topaz and albite. Redistribution of metals in sulphides gave rise to the formation of pockets of Bi-Ag-rich sulphides (Karup-Møller 1973).

The formation of the fluorite-cryolite seems to have taken place in a period of violent mechanical and chemical activities involving the consolidated products of the first

Fig. 2. Map of Ivigtut showing the coastline 1859, the edge of the mine in 1889 and in 1962. The vertically ruled area indicates maximum extension of the cryolite body, the squared area the outcrop in 1859. The pegmatite occupied the area with vertical/inclined ruling. In this area outlines of the old drifts are marked. The shaded area marks the position of BCrbF as reported in 1889. Niches in the S-wall of the old mine are indicated. Cryolithionite finds are marked "x" and numbered.

On the longitudinal section L_v-L_o the outline of the cryolite body; the broken line (lower left part) delineates the body of pure white cryolite. "A" and "B" indicate projections of the two shafts from 1867. Black areas and dots represent BCrbF. "x" with numbers, represent projections of cryolithionite finds.

Outlines of quarry in 1889, 1951 and 1962 are marked together with the transport tunnel from 1949.

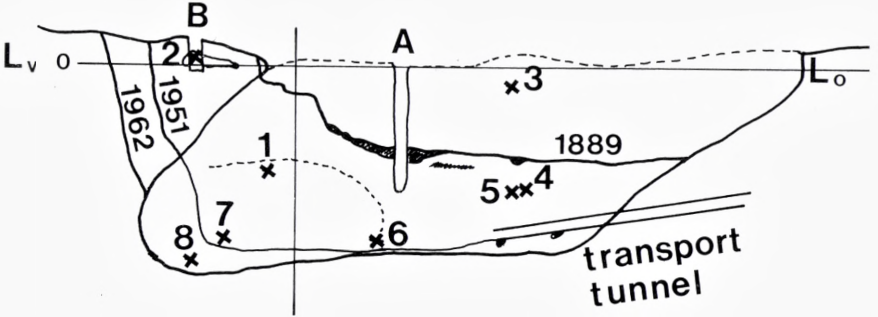
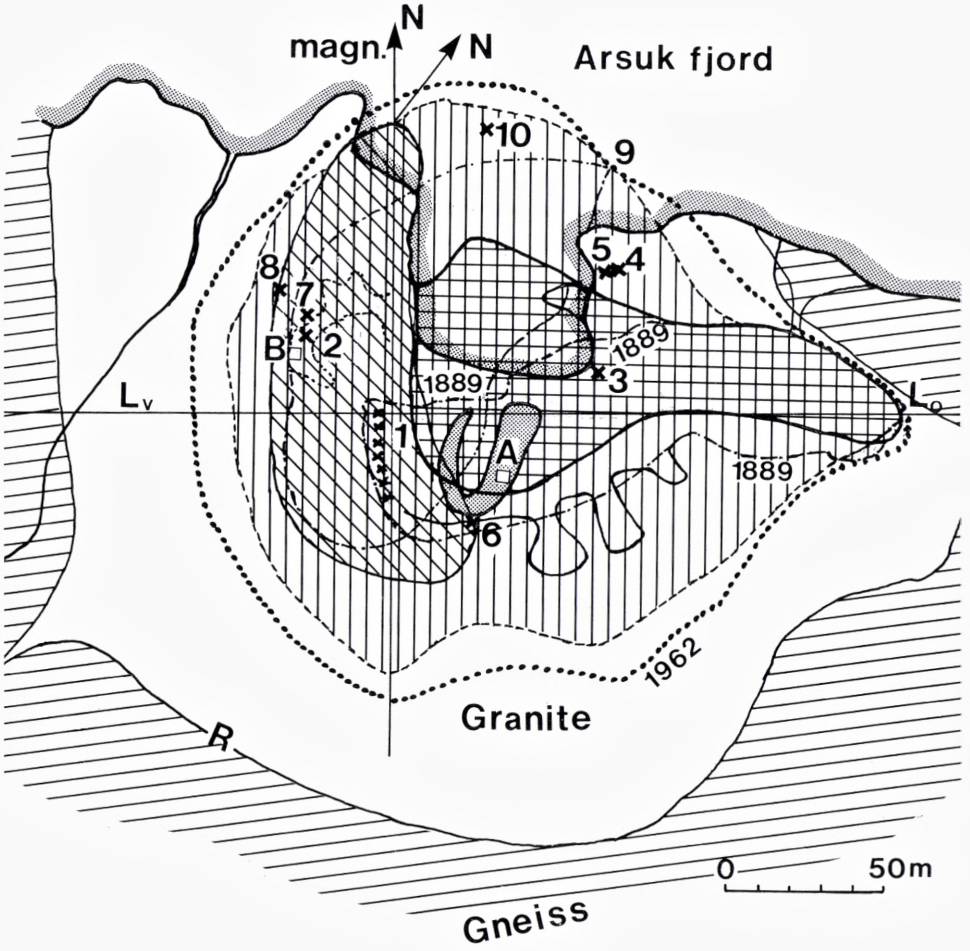

period. The position of the fluorite-cryolite within the deposit, next to the body of pure, white cryolite, suggests that substantial amounts of this body were converted to fluorite-cryolite. The mineral chiolite, found in quantities in fluorite-cryolite, was probably a component of the body of pure, white cryolite (Pauly 1986). Following incorporation in the fluorite-cryolite, chiolite was not only shattered and broken up but it decomposed to cryolite and topaz as can be seen marginally and along cracks in all samples of the mineral (Pauly 1986). Chiolite was clearly unstable under the conditions which gave rise to the fluorite-cryolite.

Veins of pure cryolite cutting through siderite-cryolite were often flanked by siderite crystals much coarser than the siderite disseminated in the surrounding cryolite. Vein formation and growth of siderite were obviously closely related. The rock xenoliths cemented by siderite-cryolite in the eastern protrusion of the deposit were found to be fringed by quartz crystals growing out into the surrounding cryolite. The cementing of this breccia obviously took place in the period when siderite-cryolite formed and quartz crystals were still in growth.

These veins of pure cryolite are regarded as early formed veins belonging to the period in which siderite-cryolite and the body of pure cryolite formed, the first period in the development of the deposit. The vein of pure cryolite cutting through BCrbF, shown in Fig. 3, likewise belongs to this period because it has well developed quartz crystal linings.

The veins of pure cryolite transecting the wall rocks along the border to the lens-shaped cryolite body may partly belong to the same period, but generally these veins, as well as the pure cryolite cementing the two chimney-like breccias, differ from the above mentioned veins: siderite is not present, quartz crystals do not line these veins and the xenoliths are not fringed by quartz crystals. The cryolite of these veins and breccias is regarded as later than the above mentioned veins.

No clear distinction can be made between veins of cryolite transecting the wall rocks and the cryolite cementing the breccias. The latter must, however, belong to the second period in the formation of the deposit in which the fluorite-cryolite developed, because blocks of chiolite, decomposed to cryolite and topaz marginally and along cracks, have been observed as xenoliths in the breccias.

According to Pauly (1982, 1984), the introduction of cryolite into these surroundings with no signs of chemical reactions or growth of quartz crystals on the xenoliths may be accounted for by its high mobility: above 450°C the mineral was found to exhibit unrestricted plastic deformation in uniaxial compression tests at atmospheric pressure.



Fig. 3. Cryolithionite to the left in vein of black cryolite transecting BCrbF and polished section cut 2 cm behind the surface. Note quartz crystals lining the vein. The polished section shows red-brown fluorite on both sides of the vein. The samples are 9 cm long.

Appearance of cryolithionite

Cryolithionite from Ivigtut is only known as inclusions in cryolite. Each inclusion is invariably found to consist of just one single crystal. The always present cleavage faces, with interfacial angles of 60° characteristic of $\{110\}$, stretch right across each inclusion from border to border.

These single crystal inclusions are most often several cm across, crystals 8 to 10 cm across were not unusual and the largest ones measured 17 to 19 cm across. In two cases (out of several hundred), crystals 1.5 cm across have been found; despite intense search smaller crystals have never been met with.

Cryolithionite in samples from BCrbF shows straight-lined borders representing $\{100\}$, $\{110\}$ og sometimes $\{211\}$, against the surrounding cryolite, Fig. 4. Where

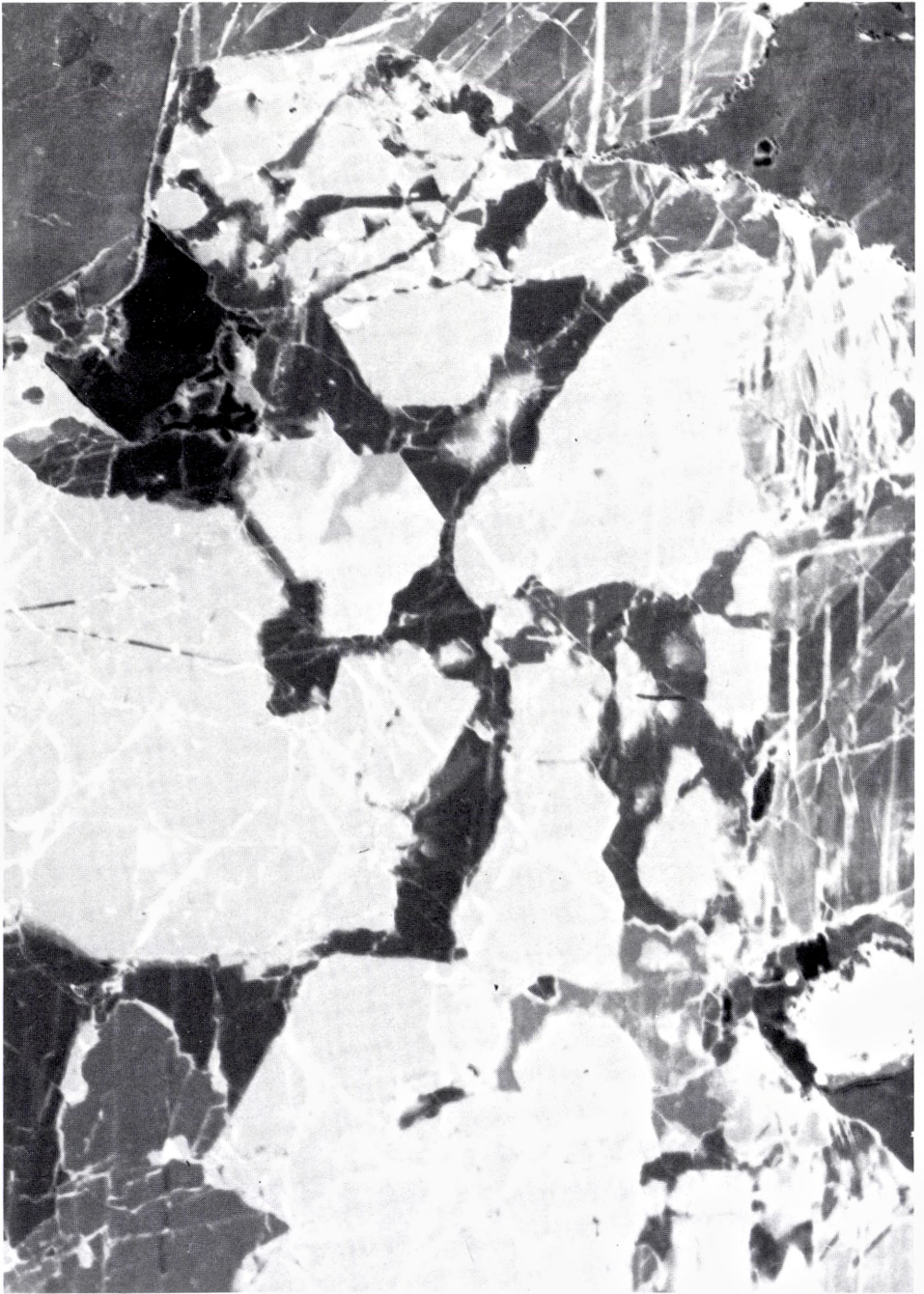

Fig. 4. Thin section of cryolithionite crystal in BCrbF. Its straight lined borders correspond to the crystal faces (100) (110) and (211). Cryolithionite light gray areas with cleavage fissures after (110) (white). Dark to nearly black areas within the crystal are cryolite. Outside the crystal is cryolite with twin lamellae. The section is 9 mm wide.

Note: thin section between crossed polaroids used as a photographic negative.

impurity minerals of the cryolite happen to lie in the contact their shapes determine the course of the borderline.

In the earliest samples, cryolithionite frequently appeared with hexagonal outlines (Ussing 1904), see Fig. 1. It is noted, however, that the borderline is quite irregular; microscopically the two minerals, cryolite and cryolithionite, are seen to be fingering into each other (Ussing 1904). No straight line borders have been observed in this type of samples.

Cryolithionite, in samples of vein cryolite, often shows the same tendency to appear with hexagonal outlines though in detail having quite irregular borderlines. Some samples contain the mineral as rounded grains; in one case it appeared to be filling a cavity with partly concave boundaries, Fig. 5.

In fluorite-cryolite the grains of cryolithionite appear as more or less equidimensional bodies. A few samples appear to contain two inclusions separated by cryolite wedging in between them. In one case the cleavage faces indicated that the two inclusions were of slightly different orientation (about 5°).

The cleavage faces {110} which can be observed in all samples have a vitreous lustre. They are stepped and rather densely freckled by mm-sized dull spots. (Microscopy of material scraped from such a spot showed it to be cryolite.) It should be noted that conchoidal fracture is also present and in some samples even dominates; by carefully turning such a sample in sharp light one can, however, see the {110} cleavage too.

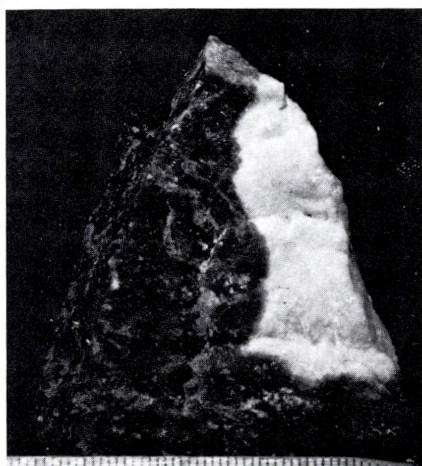

Fig. 5. Cryolithionite crystal (white) with concave outline in black cryolite. Sample 6 cm high.

Cryolithionite may enclose the same minerals as are present in siderite-cryolite and in BCrbF. They appear scattered through the cryolithionite in much the same way as they are distributed in the cryolite. Small blebs of cryolite which are often seen in siderite, quartz and red-brown fluorite when they lie in cryolite, can also be found when these minerals are included in cryolithionite.

In contrast cryolithionite from fluorite-cryolite has not been found to include the impurity minerals of this cryolite type in a similar manner. The admittedly highly irregular patterns of veins of microcrystalline topaz and K-mica are not seen as inclusions but in some cases thin veins of these minerals can be seen penetrating the margins of the cryolithionite from the surrounding cryolite. In several samples scattered, small grains (less than one mm in size) of siderite have been found in the cryolithionite although siderite does not belong to the fluorite-cryolite.

Samples of vein cryolite only contain macroscopically pure cryolithionite.

When the surrounding cryolite has been subject to secondary alterations, giving rise to the formation of thomsenolite, ralstonite etc, these secondary minerals can also be found within the cryolithionite.

Microscopy shows all samples of cryolithionite to contain cryolite as a major admixture and in all samples fluid inclusions of rather conspicuous sizes are observed.

The cryolite inclusions are remarkable: they are disseminated throughout the crystals in highly irregular shapes but present constant optical orientations over large areas of the section as also observed by Ussing (1904). He compared the texture to that of a micropegmatite.

The large thin sections (5 to 10 cm across: polished on both sides) used in the present examination showed that the cryolite surrounding the cryolithionite contained several systems of polysynthetic twin lamellae. Four or five of the seven twin laws known to occur in massive cryolite (Bøggild 1912, Pauly 1979), have been observed in the surrounding cryolite where they (as usual) constitute a rather complex pattern of lamellae. The patterns of the surrounding cryolite reveal the presence of several differently oriented cryolite grains enclosing the cryolithionite. The cryolite inclusions within the cryolithionite are distinctly different in appearance: they may be untwinned, two differently oriented parts of an inclusion may exhibit a straight line border indicating the presence of a simple twin and in one thin section of a crystal from BCrbF, Fig. 4, the twin law $(021)^{120}$ was identified in the cryolite included in the crystal.

Along the margins of the cryolithionite crystals, irregularly shaped embayments of the surrounding cryolite with its complicated systems of polysynthetic twin lamellae are present. They may even appear totally surrounded by cryolithionite but this is probably only a result of the two-dimensional nature of the thin section. It should be noted that the twin patterns of the marginal inclusions are continuous with those of the surrounding cryolite.

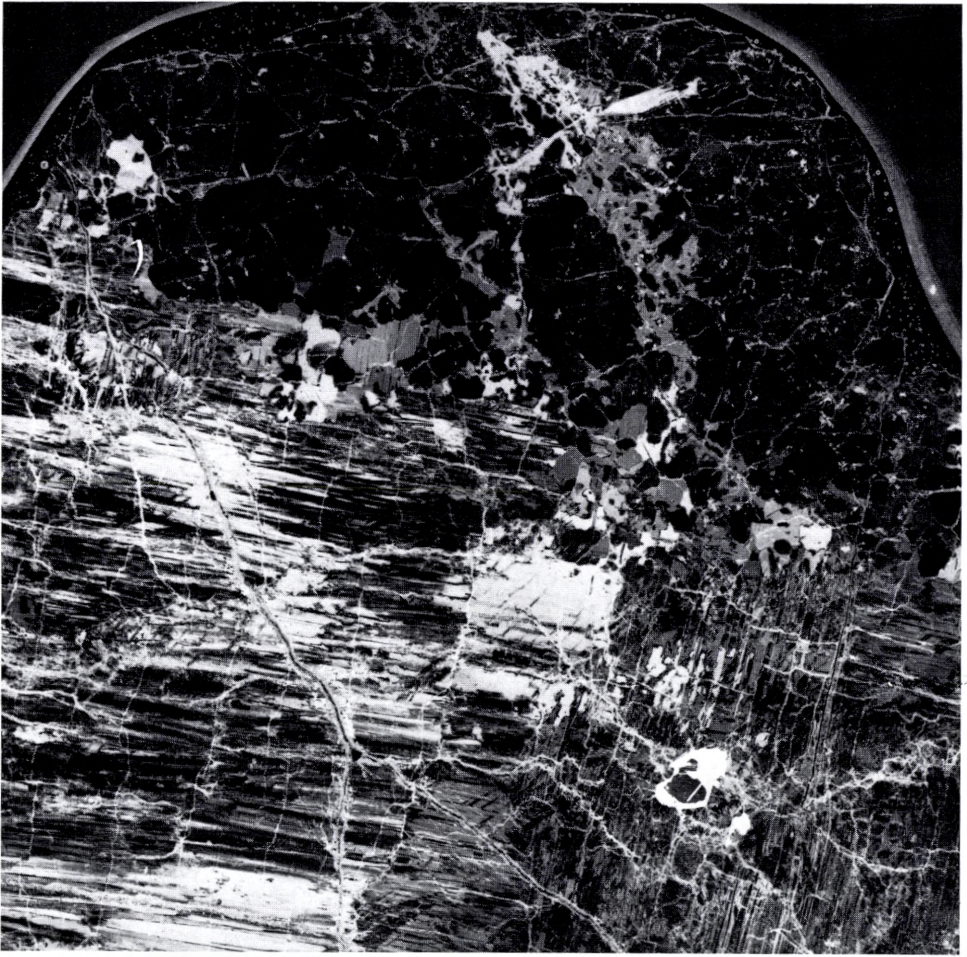

Fig. 6. Thin section of cryolithionite crystal in white cryolite. // N.

Note the irregular border between the crystal, black, and surrounding cryolite with numerous thin twin lamellae. Grey to white, smooth areas in the crystal and as clusters along the border are untwinned cryolite formed together with the cryolithionite. The thin section is 4 cm wide.

The thin section between polaroids used as the photographic negative.

A number of small (50 to 100 μm in diameter) rounded grains of cryolite have been seen included within areas of cryolithionite. The optical orientation varied from grain to grain. This seems to indicate a tendency to poikilitic intergrowth.

Although the shapes of the cryolite inclusions within the crystals are highly irregular there are often straight borders between the two minerals. Cryolithionite may show idiomorphic borders towards the cryolite also in its interior parts.

With regard to the two types of cryolite inclusions: those showing polysynthetic twin structures in continuation of the surrounding cryolite and the simply built inclusions, it should be noted that the latter sometimes form accumulations along the borders between cryolithionite and the surrounding cryolite as seen in Fig. 6.

In thin sections (as well as in polished sections), large, irregularly shaped fluid inclusions can be seen in the cryolithionite. Ussing (1904) found that they had a high gas to liquid ratio and the gas bubbles might be up to 0.2 mm across. Daughter minerals, cubes 10–20 μm across, have been seen in the gas-filled parts of the inclusions. In one case such cubes observed in a liquid-filled vacuole had a lower refractive index than the liquid, cryolithionite also had a lower refractive index than the liquid, but its relief was not as strong as that of the cubes. They may be NaF (villiaumite crystals).

A polished section was vacuum impregnated before polishing. The finished section revealed that the yellow coloured impregnation medium penetrated deep into the mineral affecting about half of the 2 by 3 cm area of cryolithionite: the large fluid inclusions seem to be interconnected over distances of more than one cm. This also seems to imply that the original content of the vacuoles cannot be assumed to be intact probably not even after a less severe treatment because the vacuoles were open to impregnation after cutting and grinding.

The borders of the fluid inclusions often appear as straight lines following the cleavage directions of the mineral. The depth of such a vacuole in one thin section was found to be 10–15 μm . These rather extensive but thin vacuoles seem to follow, in a general way, the cleavage planes of the mineral $\{110\}$. Subsurface reflections in polished sections often showing low-order interference colours support this. SEM examinations of a fresh cleavage face, Fig. 7, showed the presence of shallow pits bounded by arrays of crystal faces.

The ready splitting of cryolithionite along $\{110\}$ planes is probably caused by the presence of the thin but large and numerous fluid inclusions following these planes, but true cleavage in these directions can hardly be ruled out because thin sections regularly show straight cracks attributable to such a cleavage.

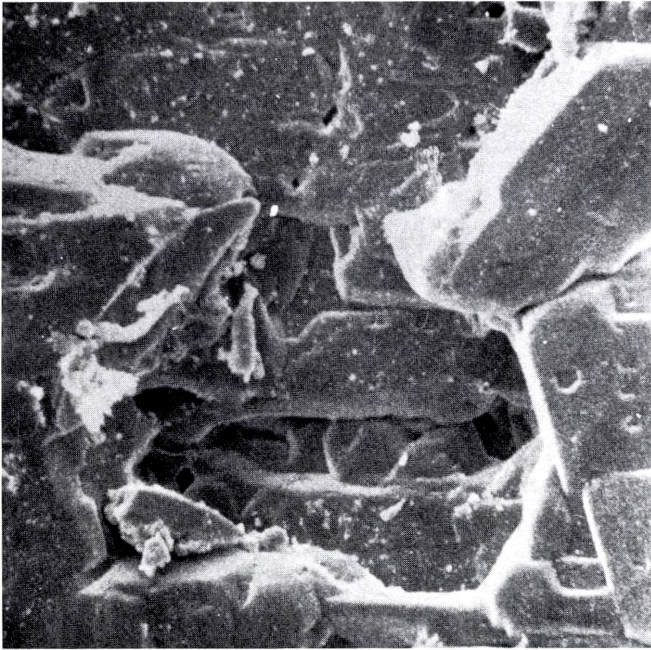

Fig. 7. SEM photograph of fresh cleavage surface of cryolithionite showing dents and shallow pits faceted by arrays of crystal faces. Magnification 400 x.

Formation of cryolithionite

The irregularly shaped embayments and marginal inclusions of the polysynthetically twinned cryolite in the cryolithionite indicate the latter to have replaced cryolite after the formation of the complicated twin structures. Yurk et al. (1973) reported gradual disappearance of twin lamellae and birefringence when cryolite was heated between 470 and 520°C. This points to an upper limit for the temperature at which growth of the cryolithionite crystals took place.

The single crystal nature of all – even the largest – cryolithionite masses seems to indicate growth under favourable conditions. The numerous, large fluid inclusions along planes of {110} indicate a certain degree of skeletal growth.

The irregularly shaped cryolite inclusions in the crystals, occasionally having straight borders on the cryolithionite, indicate that cryolite formed – or recrystallized – together with or in the closing stage of the development of the skeletally grown crystals.

The rectilinear borders of the crystals towards the surrounding cryolite in samples from BCrbF show these samples to contain strictly idiomorphic crystals in contrast to the subidiomorphic crystals which indicate somewhat reduced growth conditions. Further deterioration of growth conditions obviously marks those surroundings in

which cryolithionite developed irregular shapes; an extreme case, Fig. 5, seems to show that the mineral filled a concave void in cryolite. The internal growth condition in all cases favoured, however, the establishment of just one crystal though always of a definite skeletal character.

These variations in outer shape of the crystals are believed to represent formation over an interval of temperature.

Cryolithionite crystals in vein cryolite have been observed to occupy up to 80% of the width of the vein; therefore they are assumed to have formed after the *mise-en-place* of the veins.

The appearance of cryolithionite in samples of fluorite-cryolite indicates that the mineral was present before the processes took place which gave rise to the fluorite-cryolite. The siderite disseminated in several cryolithionite crystals from these surroundings are in agreement with this since the inclusions of siderite obviously were protected from the transforming processes which otherwise would have broken down the carbonate in the fluorite-cryolite milieu, see page 8.

Cryolithionite, being older than the fluorite-cryolite, must have formed above 300°C as part of the fluorite-cryolite formed around this temperature (Karup-Møller 1973).

Li in cryolite and other minerals from the Ivigtut deposit

Pure cryolite separated from the different varieties of cryolite has been analysed for Li (by atomic absorption spectrophotometry) with the results given in Table 1. The average of all samples was $\bar{X}_{268} = 92$ ppm (min. 19, max. 224 ppm). Several samples of cryolite with the highest concentrations have been carefully examined in thin sections and cryolithionite was not detected in any of them. The Li is therefore assumed to represent a solid solution of Li_3AlF_6 in the analysed cryolite.

Among the 268 samples were 14 in which the mineral cryolithionite was present elsewhere in the samples. Cryolite from these samples gave $\bar{X}_{14} = 80$ ppm Li (min. 38, max. 107 ppm). Six of these samples were of black cryolite from BCrbF and gave 89 ppm Li (min. 69, max. 107 ppm), the other 8 gave 71 ppm (min. 38, max. 93 ppm) against the average of 185 ppm Li (min. 139, max. 222 ppm) for 14 samples of cryolite from BCrbF in which cryolithionite was not found.

Crystals of cryolite from linings of cavities in three samples of siderite-cryolite did not show detectable amounts of Li (detection limit 0.2 ppm Li). Cryolite from elsewhere in two of these samples contained 82 ppm Li.

Table 2 shows the frequency distribution within the five types of cryolite.

Analyses of a number of other minerals from Ivigtut, Table 3, show that Li is present in insignificant concentrations in the other fluorides apart from jarlite from the

Table 1: Average, minimum and maximum content of Li (in ppm) in cryolite from the five cryolite ore types. The averages for cryolite containing below/above 120 ppm Li are given in the last two columns.

Cryolite type	Average values	Min.	Max.	Below 120 ppm	Above 120 ppm
Siderite-cryolite	$\bar{X}_{78} = 83$	19	224	$\bar{X}_{66} = 84$	$\bar{X}_{12} = 159$
Black cryolite with red-brown fluorite	$\bar{X}_{21} = 153$	69	222	$\bar{X}_7 = 90$	$\bar{X}_{14} = 185$
Pure white cryolite	$\bar{X}_{132} = 87$	34	190	$\bar{X}_{112} = 78$	$\bar{X}_{20} = 138$
Smoky cryolite from veins	$\bar{X}_{14} = 78$	46	101	$\bar{X}_{14} = 78$	0
Fluorite-cryolite	$\bar{X}_{23} = 101$	38	158	$\bar{X}_{16} = 84$	$\bar{X}_7 = 138$
	$\bar{X}_{268} = 92$	19	224	$\bar{X}_{215} = 76$	$\bar{X}_{53} = 155$

fluorite-cryolite. The fine-grained K-mica, likewise the fluorite-cryolite, was found to contain Li comparable to the Li content of the cryolite. Biotite from the pegmatite sheet belonging to the top part of the granite intrusion (see Karup-Møller and Pauly 1979), contained half a percent of Li. Zinnwaldite from a single sample from the southern margin of the deposit came out with one and a half percent of Li.

Calculations based on the estimated total mineralogical composition of the lens-shaped body of cryolite show that more than 90% of the Li present was contained in the cryolite; only 3 percent was present in the fine-grained K-mica. An estimate of the total number of samples of cryolithionite collected since 1902 multiplied by one hundred would contribute less than one ppm to the Li content of the cryolite of the deposit.

Cryolithionite formed by exsolution of Li from cryolite

Cryolite at 500°C can dissolve 16 mol% Li_3AlF_6 (Cassidy & Brown 1979); this corresponds to 1.82% Li by weight. The average Li content of cryolite from Ivigtut is seen to be one half percent of the solubility at 500°C. Twenty percent of the samples - containing more than 120 ppm Li - held an average of 155 ppm. Among these were the

Table 2: Frequency distribution of Li in cryolite from the five cryolite types: pure, white cryolite (PwC), siderite-cryolite (SC), fluorite-cryolite (FC), vein cryolite (VC), black cryolite with red-brown fluorite (BCrbF).

	1-10	11-20	21-30	31-40	41-50	51-60	61-70	71-80	81-90	91-100	101-110	111-120	121-130	131-140	141-150	151-160	161-170	171-180	181-190	191-200	201-210	211-220	221-230
PwC	-	-	-	4	6	8	19	27	26	8	7	7	10	3	4	-	2	-	1	-	-	-	-
SC	-	1	5	5	5	8	10	9	11	5	6	1	3	1	1	2	1	-	2	1	-	-	1
FC	-	-	-	1	1	4	-	-	-	5	2	3	3	2	1	1	-	-	-	-	-	-	-
VC	-	-	-	-	2	-	3	1	4	3	1	-	-	-	-	-	-	-	-	-	-	-	-
BCrbF	-	-	-	-	-	-	1	1	2	1	2	-	-	1	-	-	1	4	4	1	2	-	1
	-	1	5	10	14	20	33	38	43	22	18	11	16	7	6	3	4	4	7	2	2	-	2

14 samples from BCrbF, their average of 185 ppm Li corresponding to one percent of the solubility at 500°C.

The comparison of these 14 samples with the samples known to contain cryolithionite and which have cryolite with only 89 ppm Li seems to indicate that cryolithionite formed through exsolution of Li from cryolite originally containing about one percent of the amount of Li which might be held in solid solution at 500°C. The conditions prevailing in the deposit at the time of exsolution still allowed half of this amount of Li to be kept in solid solution.

Crystals of cryolite such as those in which Li could not be detected are regarded as products of dissolution and redeposition caused by very pure water trapped in isolated cavities and fissures (because no other minerals are present together with the cryolite crystals). The conditions under which they formed, low temperature and low pressure, did not allow Li to be incorporated in their lattices.

In judging the assumption that cryolithionite formed through exsolution of Li from a rather diluted solid solution in cryolite it may be of interest to note the following properties of the two minerals:

The calculated densities of cryolite and cryolithionite, at room temperature, are 2.973 and 2.771 respectively. One may thus regard the crystals of cryolithionite as representing low density spaces within the cryolite.

Table 3: Lithium content (in ppm) in minerals from the cryolite deposit, Ivigtut, S-Greenland.

Chiolite	8	Mica, finegrained	111-315
“Topaz-cryolite”*	5	Mica, mm-sized	60
Weberite	16-29	Biotite from pegmatite	5812
Jarlite**	400-800	do.do. altered	232
Thomsenolite	2	Zinnwaldite	16710
Prosopite	4		
Gearsutite	20	Cryolithionite	56000
Red-brown fluorite	0	Cryolite	92
Cryolite crystals	0		

* Cryolite with ab. 1% microcrystalline topaz, a reaction product from decomposition of chiolite.

** From Bøgvad 1933.

Cryolite, when cooled from 500°C to room temperature, is estimated to contract about 1 vol% per 100°C (Pauly 1984). The contraction of cryolithionite is slightly less according to the data given in Holm & Holm (1970).

Above 450°C cryolite has been found to exhibit unrestricted plastic deformation in uniaxial compression tests at atmospheric pressure (Pauly 1984). This is consistent with the disappearance of the twin lamellae observed to start when the mineral is heated to temperatures above 470°C (Yurk et al. 1973).

Regarding exsolution of Li from cryolite as taking place through diffusion processes it is of interest to note that the empirical rule of Tammann shows noticeable velocities for diffusion at temperatures around 460°C corresponding to half the temperature of melting (in Kelvin). Stresses and imperfections in the cryolite enhance the diffusion process.

As long as cryolite is held at temperatures at which it behaves as a ductile substance contraction on cooling will not create stresses within the mass: plastic flow will counteract stress accumulations. At lower temperatures stress accumulations and regions of low pressure will arise. The uniaxial compression tests at atmospheric pressure, referred to above, would indicate this to take place at temperatures below 450°C. The presence of cryolite with polysynthetic twin lamellae in the marginal zone of the cryolithionite indicates replacement of cryolite to have taken place below 470°C.

Confining pressure enhances ductility. When siderite-cryolite formed, confining pressure is assumed to have been around 1500 bars (Oen & Pauly 1967). Ductility may therefore be assumed to prevail at temperatures slightly below 450°C.

So far cryolithionite seems to have formed in a temperature interval somewhere below 450°C but above 300°C.

In the system $\text{Na}_3\text{AlF}_6\text{-Li}_3\text{AlF}_6$ also exists, besides cryolithionite, $\text{Na}_2\text{LiAlF}_6$ as a stable phase below some 500°C (Garton & Wanklyn 1967, Holm & Holm 1970). According to the latter reference its density is 3.021 at 20°C. The average refractive index of this monoclinic compound is $n = 1.355$ (Pauly 1982a). No mineral with these optical properties has been found in the samples used in the present study, nor in any other sample from Ivigtut. The absence of this compound from the cryolite body is here assumed to be related to its higher density. Within the cooling cryolite, shrinking created low pressure regions where the low density compound cryolithionite formed successively instead of the creation of a void. The stresses building up low pressure regions in the cryolite so to say provoked the exsolution of Li from the rather diluted solid solution of Li in the mineral.

The replacement of cryolite by cryolithionite may be represented by the following reaction:



Since cryolithionite takes up 95% of the volume held by the original cryolite the reaction does not really fit the picture of a volume by volume replacement. The numerous, large fluid inclusions can only account for a minor part of the discrepancy. More important are the cryolite inclusions in the interior of the crystals as they seem to have formed penecontemporaneously with the cryolithionite. The analyses of a macroscopically pure piece of cryolithionite (Ussing 1904) showed, by calculation, the presence of about 11% cryolite. The uneven distribution of these cryolite inclusions, see Fig. 6, may account for the excess amount of cryolite indicated by the mentioned analysis.

Formation of a cryolithionite crystal within a mass of cryolite containing 155 ppm Li would demand extraction of Li from a sphere with a radius 4.5 times the diameter of the crystal provided half the amount of Li remains in the cryolite. For crystals 5 cm across this gives a sphere 22.5 cm in radius. The largest crystals would need diffusion of Li from distances up to 75 cm away from the crystal. The volumes of the crystals might be created by cooling the involved masses of cryolite about 15°C.

If the formation of cryolithionite is closely related in time to the formation of the polysynthetic twin structures one might assume some of the more complicated rearrangements of the ions in the lattices to be a cooperative factor in the liberation of the Li from the cryolite lattice.

Acknowledgments

The author gratefully acknowledges the granted access to the archives of the Geological Museum of the University of Copenhagen and of Kryolitselskabet "Øresund" A/S. Mr. Sinh Hy Nguyen is warmly thanked for the carefully executed chemical analyses and Mr. Ib Nielsen for the large, polished thin sections. Useful comments were given by Dr. J. Bailey who kindly perused the draft manuscript.

Literature

- Baldauf, R. 1910: Über das Kryolith-Vorkommen in Grönland. *Zeit. für prakt. Geologie*, XVIII Jahrgang Hf. 11/12, Berlin, p. 432-446.
- Bøggild, O. B. 1912: Krystallform und Zwillingsbildungen des Kryoliths, des Perowskits und des Boracits. *Zeit. Krystallogr.* 50, p. 349-429.
- Bøggild, O. B. 1913: Beobachtungen über die Mineralien der Kryolithgruppe. *Zeit. Krystallogr.* 51, p. 591-613.
- Bøgvad, R. 1933: New Minerals from Ivigtut, Southwest Greenland. *Meddelelser om Grønland*, 92, nr. 8, p. 1-11.
- Cassidy, Roger T. and Brown, Jr. Jesse J. 1979: Phase Equilibria in the System $\text{LiF-AlF}_3\text{-Na}_3\text{AlF}_6\text{-Al}_2\text{O}_3$. *Journal of The American Ceramic Society*, Vol. 62, No. 11-12, p. 547-551.
- Corp, S. O. 1928: Grönländsk Bergshantering. *Teknisk Tidskrift, Bergsvetenskap* 5, Årg. 58, p. 33-39.
- Garton, G. and Wanklyn, B. M. 1967: Reinvestigation of the System $\text{Na}_3\text{AlF}_6\text{-Li}_3\text{AlF}_6$. *Journal of The American Ceramic Society*, Vol. 50, No 8, p. 395-399.
- Geller, S. 1971: Refinement of the crystal structure of cryolithionite $\text{Na}_3\text{Al}_2(\text{Li}_3)\text{F}_{12}$. *The American Mineralogist*, Vol. 56, p. 18-23.
- Holm, J. L. and Holm, B. Jensen 1970: Phase Investigations in the System $\text{Na}_3\text{AlF}_6\text{-Li}_3\text{AlF}_6$. *Acta Chemica Scandinavica* 24, p. 2535-2545.
- Holst, N. O. 1886: Berättelse om en år 1880 i geologiskt syfte företagen resa til Grönland. *Sveriges geologiska Undersökning. Ser.C. No. 81*, 68 pp.
- Jarl, C. F., 1909: *Fabrikken Øresund 1859-1909*. København, 88 pp.
- Johnstrup, J. F. 1880: Kryolitens Forekomst i Grönland. 12^{te} Skandinaviska Naturforskaremötet's Förhandlingar, Stockholm, p. 234-252.
- Karup-Møller, S. 1973: A gustavite-cosalite-galena-bearing mineral suite from the cryolite deposit at Ivigtut, South Greenland. *Meddelelser om Grønland*, 195, 5, 40 pp.
- Leonardsen, Erik S., Pauly, Hans, Petersen, Ole V. and Rønsbo, Jørn G. 1980: Retrieval of wulfenite from the cryolite deposit, Ivigtut, South Greenland. *Bull. geol. Soc. Denmark*, vol. 29, p. 145-150.
- Menzer, G. 1927: Die Kristallstruktur von Kryolithionit. *Zeit. Kristallogr.* 66, p. 457-458.
- Menzer, G. 1930: Die Kristallstruktur von Kryolithionit. *Zeit. Kristallogr.* 75, p. 265-287.
- Oen Ing Soen and Pauly, Hans 1967: A sulphide paragenesis with pyrrhotite and marcasite in the siderite-cryolite ore of Ivigtut, South Greenland. *Meddelelser om Grønland, Bd. 175, No. 5*, 55 pp.

- Pauly, Hans 1960: Paragenetic relations in the main cryolite ore of Ivigtut, South Greenland. N. Jb. Miner. Festband Ramdohr, 94, p. 121-139.
- Pauly, Hans 1962: Sort og hvidt/violet/Kryolit fra Ivigtut. Meddelelser fra Dansk Geologisk Forening, Bd. 15 p. 145.
- Pauly, Hans 1979: Twins in cryolite types from Ivigtut, South Greenland. Bull. geol. Soc. Denmark, vol. 27, Special Issue, p. 7-14.
- Pauly, Hans 1982: Plasticity of cryolite and brecciation in the cryolite deposit, Ivigtut, South Greenland. In: Ore Genesis - The State of the Art. Ed. G. C. Amstutz et al. Springer-Verlag Berlin Heidelberg, p. 345-350.
- Pauly, Hans 1982a: Gladstone-Dale calculations applied to fluorides. Canadian Mineralogist. Vol. 20 p. 593-600.
- Pauly, Hans 1984: Mechanical properties of cryolite from Ivigtut, South Greenland. Bull. geol. Soc. Denmark, Vol. 33, p. 401-413.
- Pauly, Hans 1986: Chiolite in the cryolite deposit in Ivigtut, South Greenland. In: Mineral Parageneses, editors I. R. Craig et al. Theophrastus Publications S. A. Athens, Greece, p. 227-247.
- Thomsen, Julius 1904: Om de i nogle grønlandske Mineralier indeholdte Luftarter. In: Oversigt over Det kgl. danske Videnskabernes Selskabs Forhandlinger, No 2, p. 53-57.
- Ussing, N.-V. 1904: Sur la cryolithionite, espèce minérale nouvelle. Bull. de l'Académie Royale des Sciences et des Lettres de Danemark, No. 1, p. 1-12.
- Yurk, Yu. U., Buruv, E. P. and Gurova, E. P. 1973: Genesis of cryolite in metasomatic rocks of the Ukrainian shield. Dokl. Acad. Sci. U.S.S.R., Earth Sci. Sect. 208: 143-145 (in Russian) from Mineral. Abstr. 1980, vol. 31, no. 3, 80-3520, p. 355.